

Surf plafond

Porte sectionnelle plafond habitat

Structure monobloc
double rail ressorts avant



Notice de pose



Sommaire

Informations générales

- Outillage recommandé 1
- Garantie, sécurité 1
- Descriptif du colis
d'accessoires onglet A

Installation

- Mise en place des
tambours onglet B
- Assemblage
du précadre onglet B
- Assemblage du tablier . . . onglet C
- Equilibrage onglet D
- Démontage onglet D
- Manœuvre onglet E

Outillage nécessaire non fourni

2 personnes sont nécessaires pour le montage

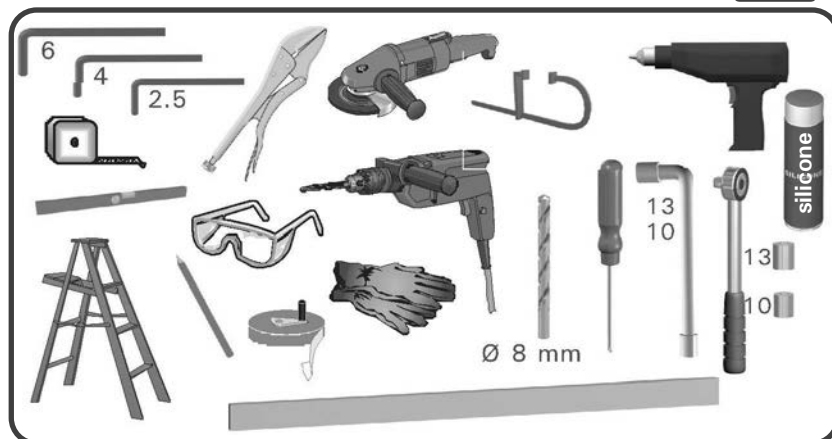

N° cde :	-
N° série :	
BE-NTC001E - 12-2013 - 11810	

Cette notice s'adresse à des professionnels de la fermeture assurant l'installation, la maintenance ou le démontage de la porte de garage. Nos produits sont livrés sans visserie de fixation au gros oeuvre : utiliser des éléments de fixation dimensionnés et adaptés au support recevant notre produit.

Garantie, sécurité

La bonne pose de ce matériel "dans les règles de l'art" est la meilleure garantie pour une utilisation optimale et une longévité accrue. Nous vous recommandons donc de suivre les indications que contient ce manuel et d'observer les règles de sécurité les plus élémentaires lors des différentes opérations de montage.

Le respect des normes européennes EN 13241-1 implique une installation en tous points conforme à ce qui est écrit dans cette notice.



























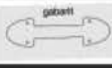

Attention : Lire attentivement cette notice avant d'utiliser votre matériel. Conserver ce document pour toute intervention ultérieure. Transmettre cette notice ainsi que la notice moteur au client final. Conformément aux normes en vigueur, cette porte de garage doit être étiquetée CE

Attention : les branchements spécifiques font l'objet de schémas (ou notices) séparés inclus aux colis d'accessoires.



PERFORMANCE ÉNERGÉTIQUE ET CONFORT DE LA BAIE

Descriptif du colis d'accessoires

Désignation	Quantité			Réf.	
	3 pa.	4 pa.	5 pa.		
Câble D3 Lg2555 Tambour étroit	1 paire	1 paire	-		11811 11809
OU	1 paire	1 paire	-		
	-	1 paire	1 paire		11812 11004
Câble D3 Lg3500 Tambour large	-	1 paire	1 paire		
Coulisse pour galet D 11	2	2	2		550
Ecrou à embase zingué Ø 6 mm	-	-	-		560
Ecrou à embase zingué Ø 8 mm	-	-	-		561
Charnière support galet galva	4	6	8		10957
Support galet haut D 11 LR	2	2	2		859
Vis autoperceuse 6.3x16 mm	-	-	-		4114
Vis métaux zinguée TRCC 6x16 mm	-	-	-		918
Vis zingue 6x16 mm jonction rail	-	-	-		923
Vis TRCC ZN M8x16 mm	-	-	-		4130
Galet Ø11 mm rallongé	4	4	4		6158
Galet tandem	4	6	8		11047
Poignée manoeuvre double ABS noire ou blanche si porte Manuelle OU Poignée d'appoint simple ABS blanc si porte Electrique	1	1	1		6740 noire 6741 blanche OU 6998 (simple)
Gabarit poignée Miami ou gabarit poignée d'appoint	1	1	1		8816 11467
Cale plastique biseautée 35x25x30x80	3	3	3		11069
Console rail double zinguée	4	4	4		9737
Suspente rail zinguée LG380	4	4	4		9735
Equerre fixation montant	10	12	14		11172
Colring incolore 3,5x280 mm	2	2	2		9915
Renfort suspente	4	4	4		11212
Support galet bas réglable	2	2	2		10251
Capot de rail horizontal DR	2	2	2		11815 (g) 11816 (d)
Equerre de barre d'écartement	2	2	2		1239
Bague arrêt (si LB>4000)	2	2	2		11808
Si porte manuelle : Sachet serrure (poignées, gâches latérales, gâche haute et visserie)	1	1	1		10082
Pied de montant	1 paire	1 paire	1 paire		12035
Notice de pose	1	1	1		11810

Mise en place des tambours

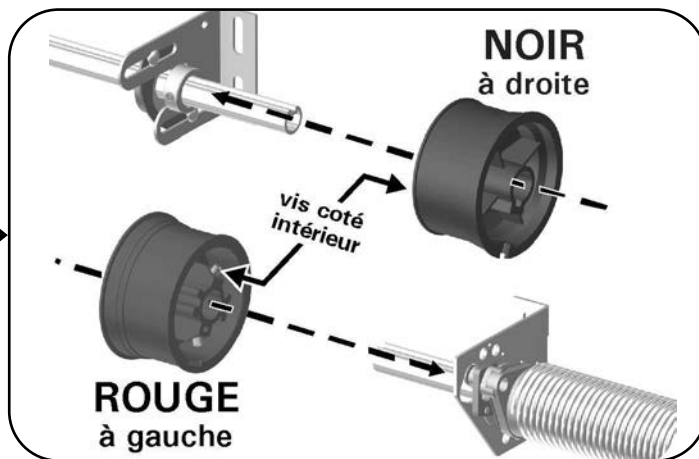
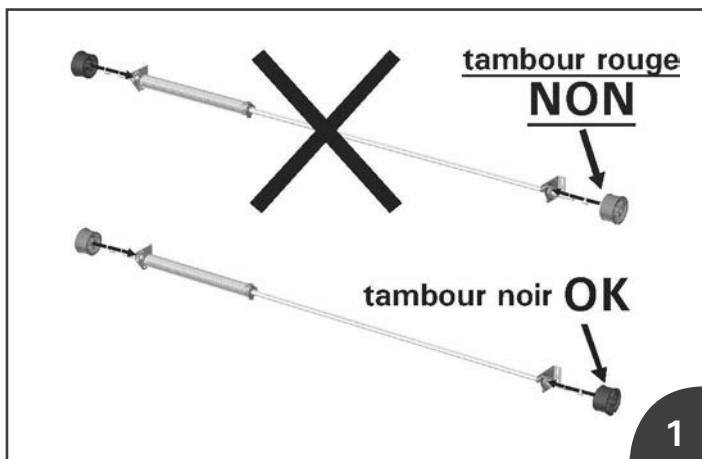

Assemblage du précadre (si porte LB > 3200, la pose de l'arbre se fait à l'étape 14b)

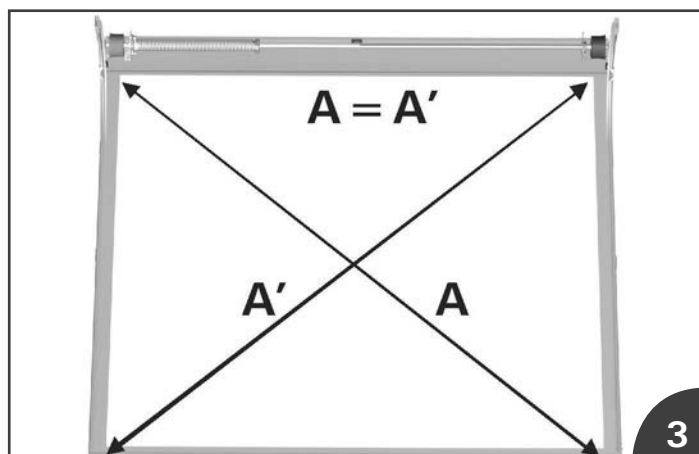
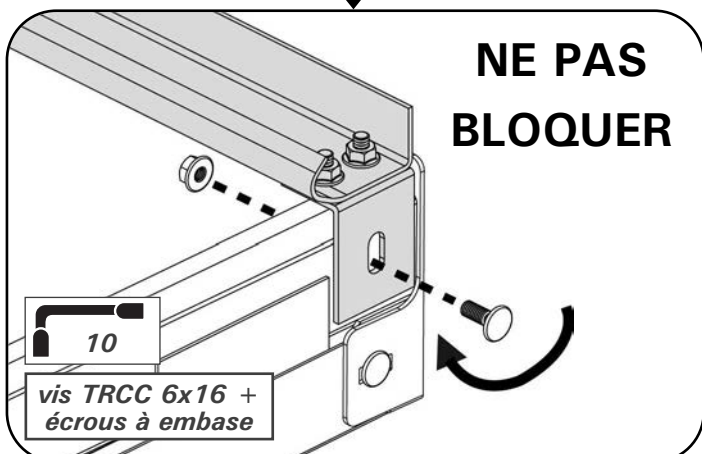
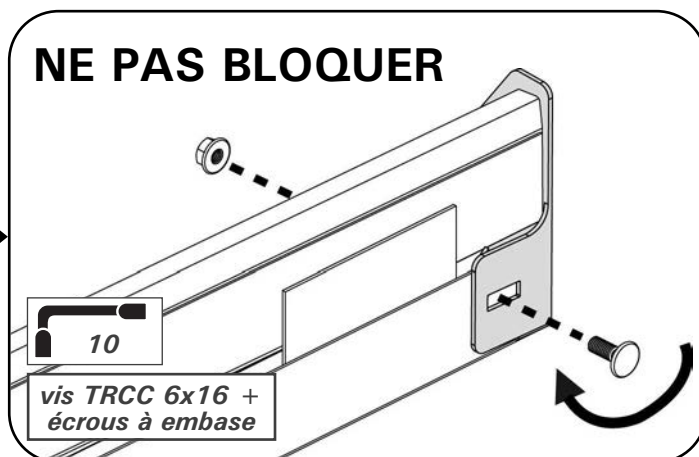
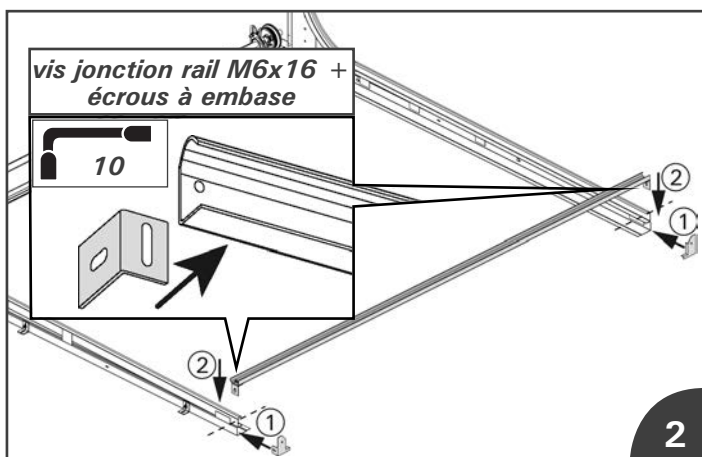
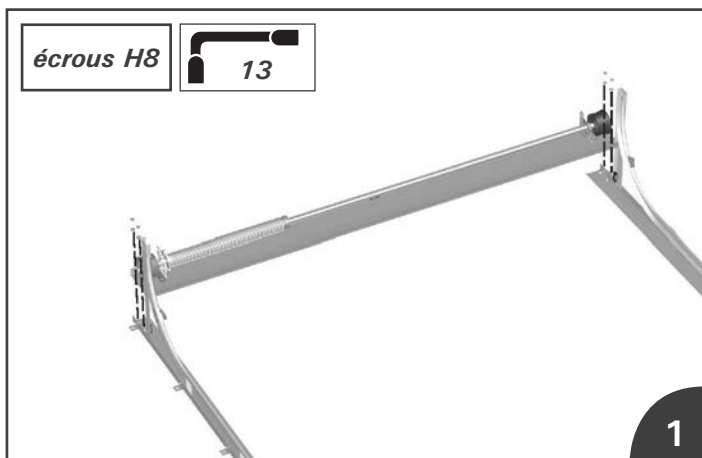

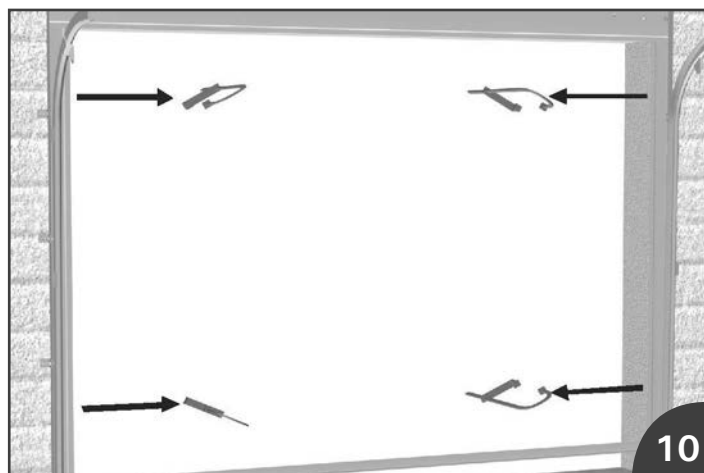
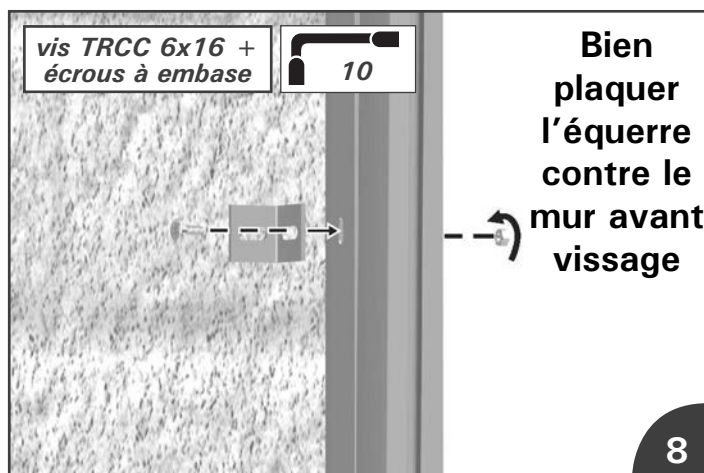
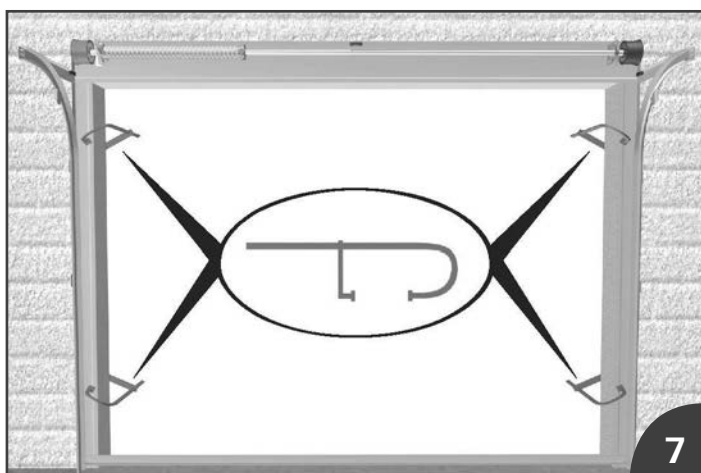
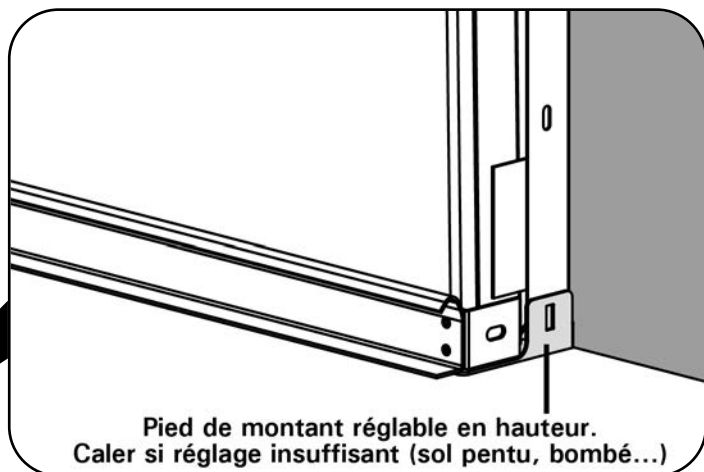
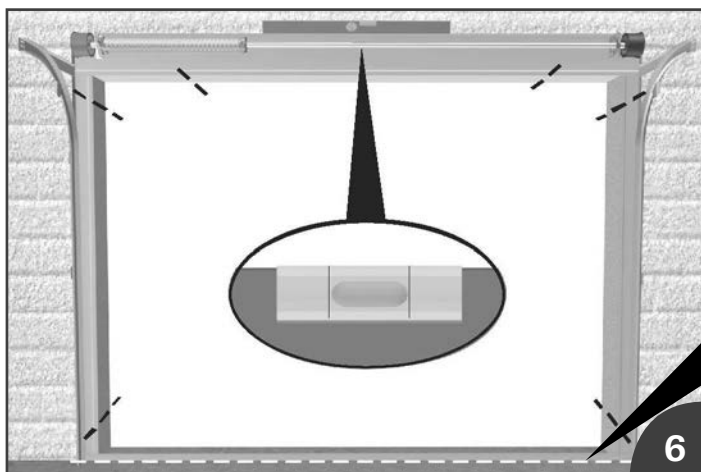
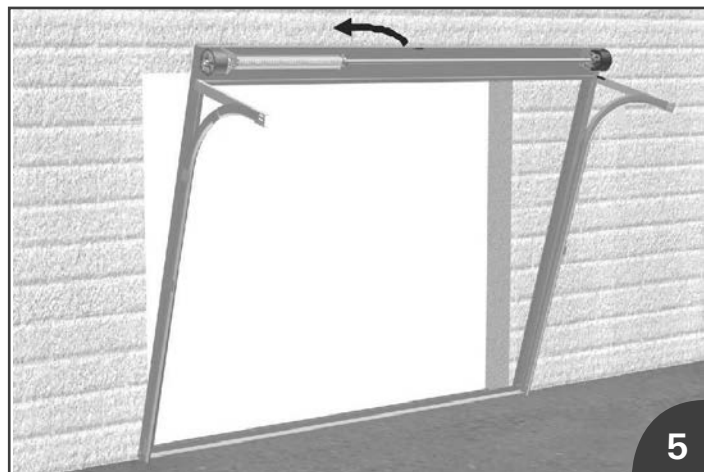
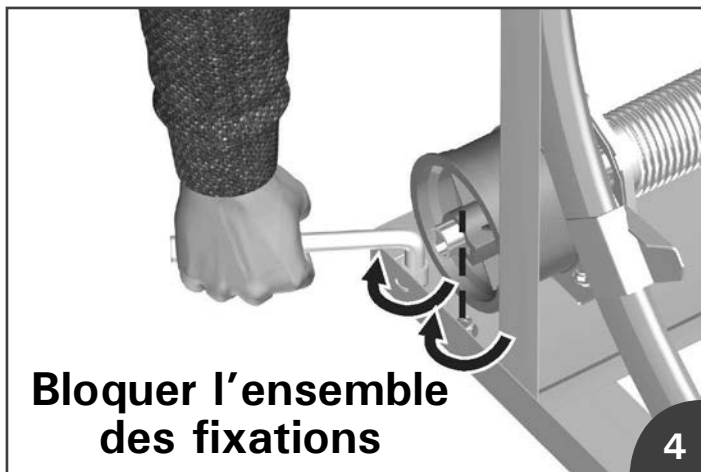

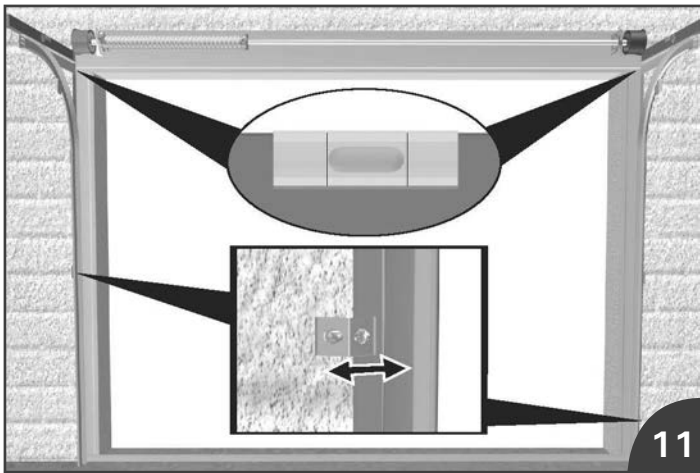

11

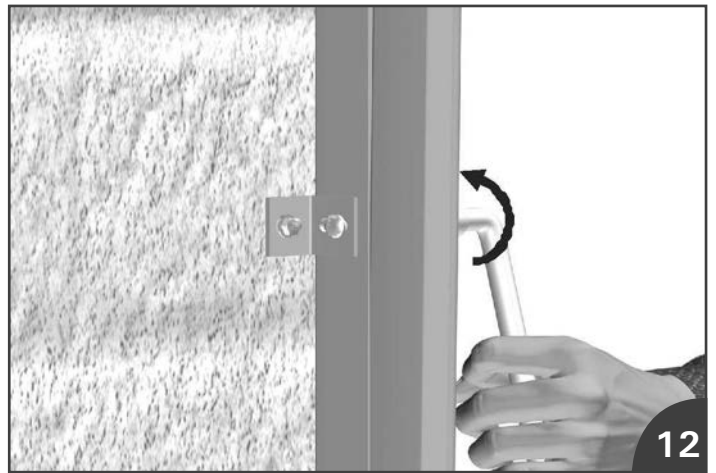

12

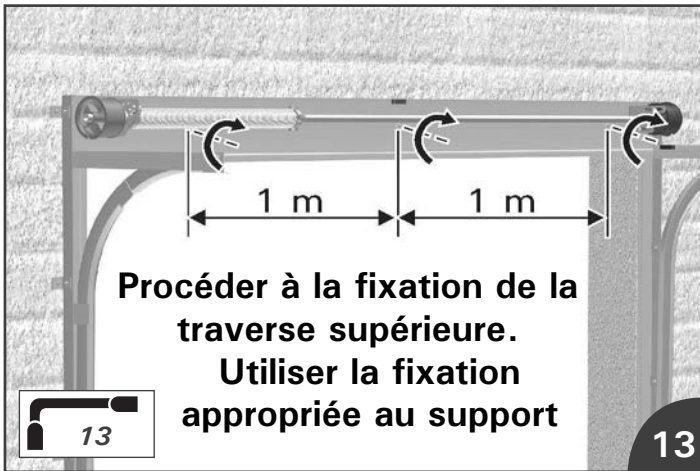

Procéder à la fixation de la traverse supérieure.
Utiliser la fixation appropriée au support

13

13

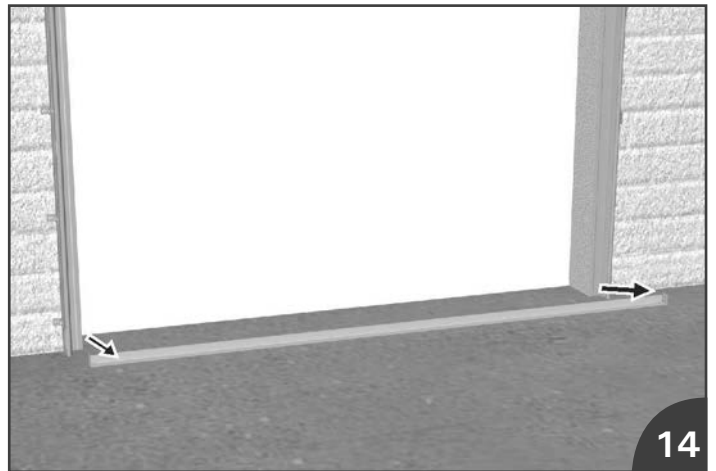

14

Cas des portes de largeur baie > 3200mm : arbre livré non monté sur la traverse

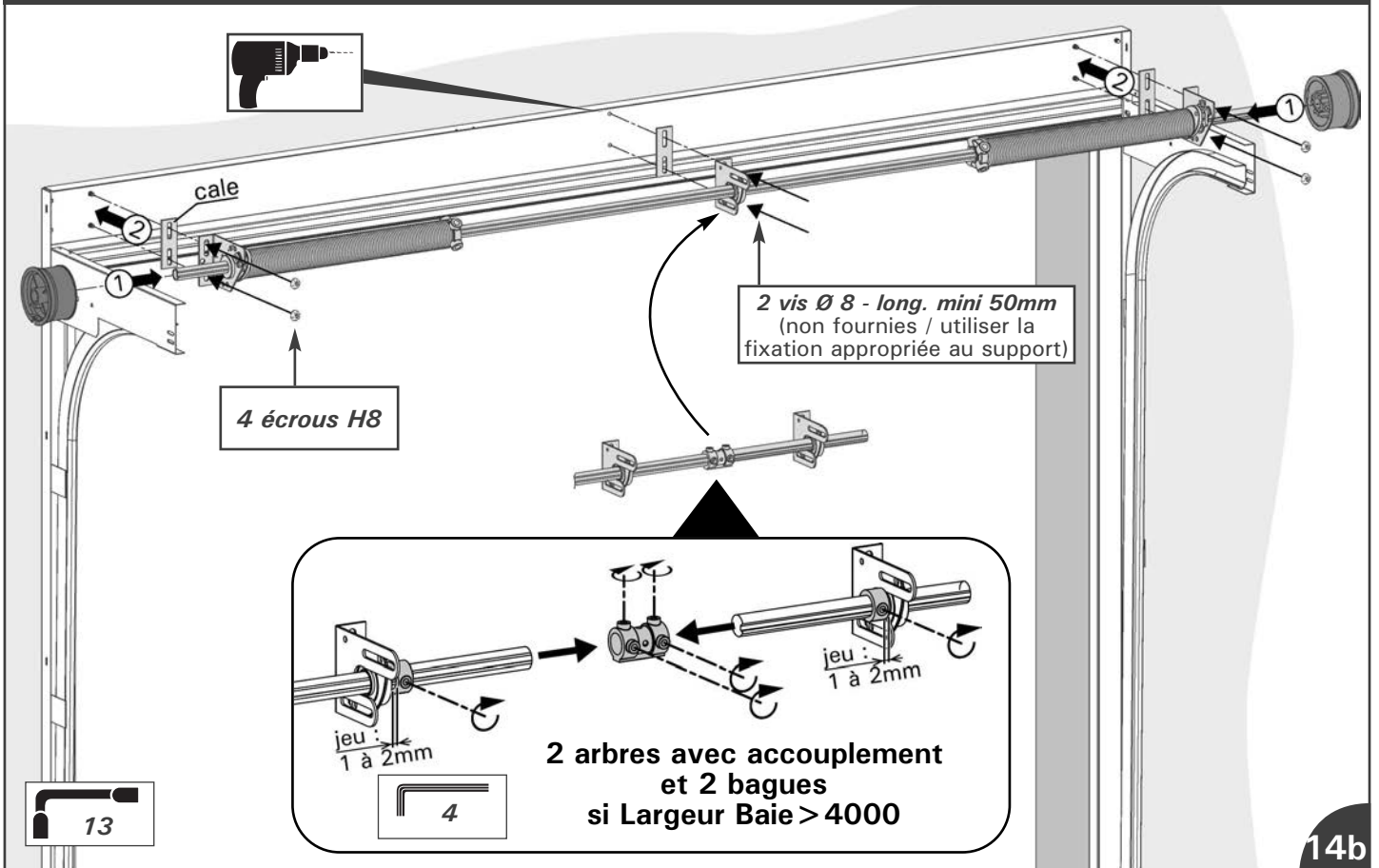

13

2 arbres avec accouplement
et 2 bagues
si Largeur Baie > 4000

4

14b

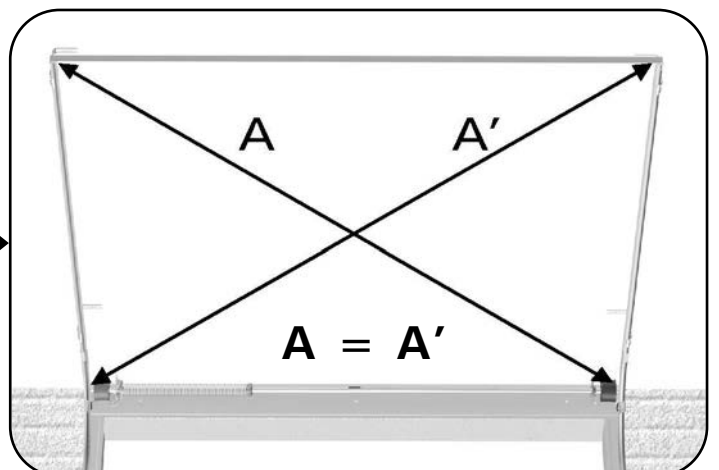
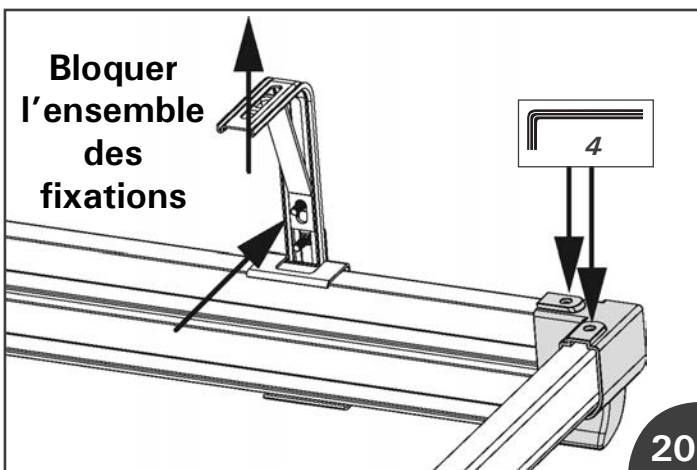
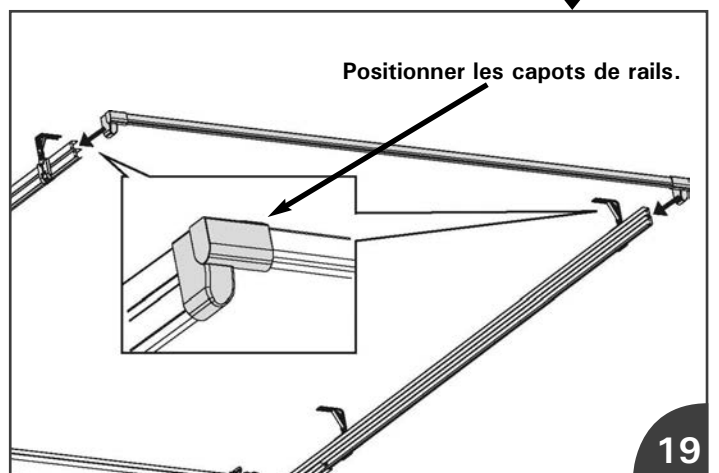
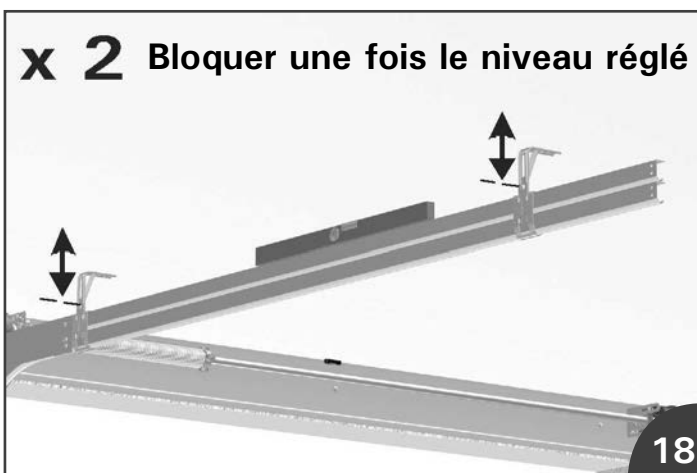
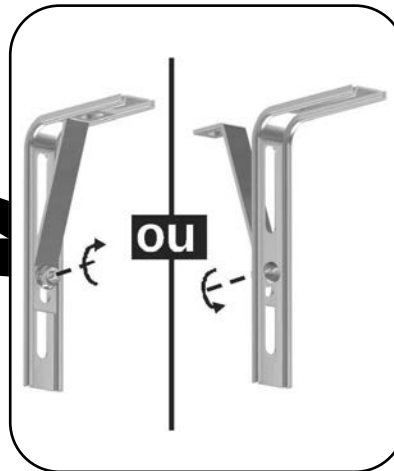
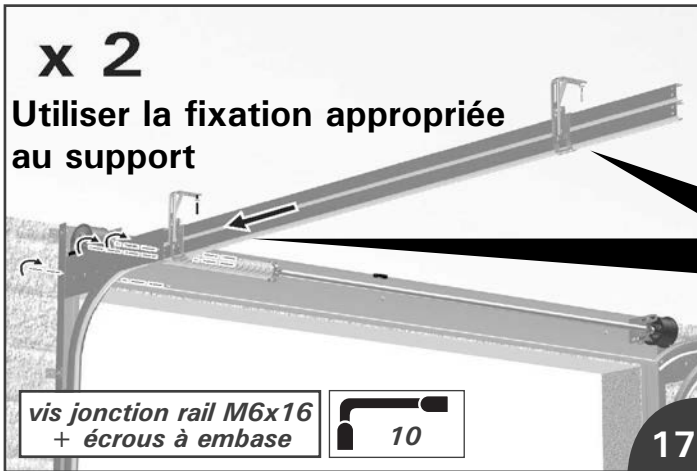
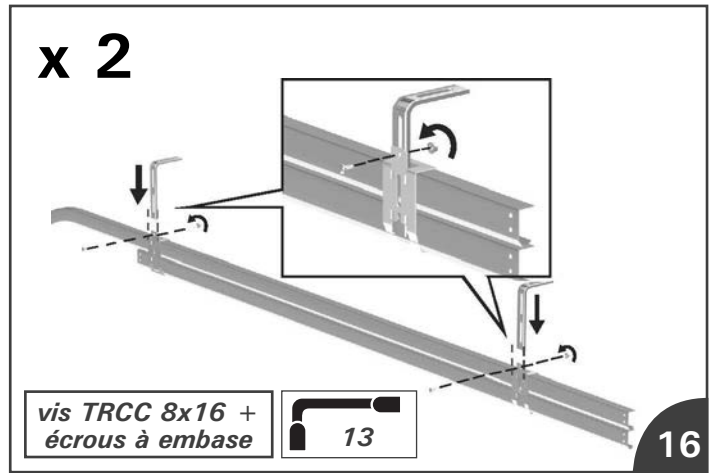
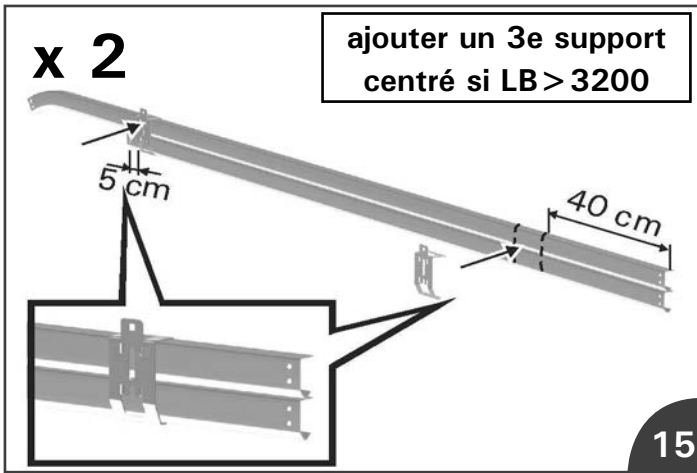

Assemblage du tablier

 *L'effort de serrage sur les vis auto-perceuses TH6.3x16 doit être modéré : 6 à 8 N.m MAXI*

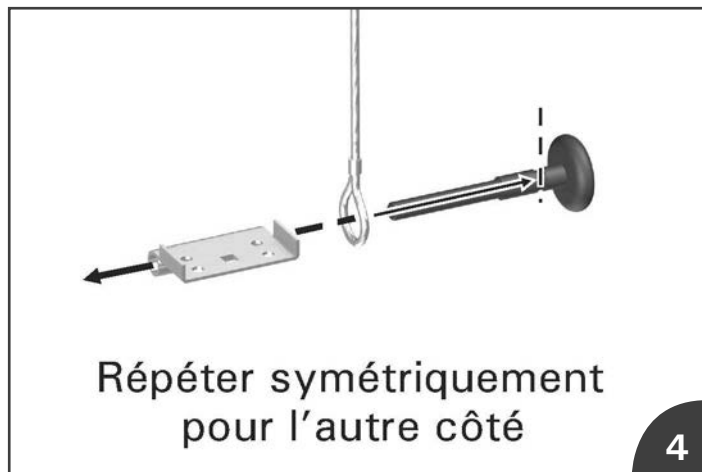
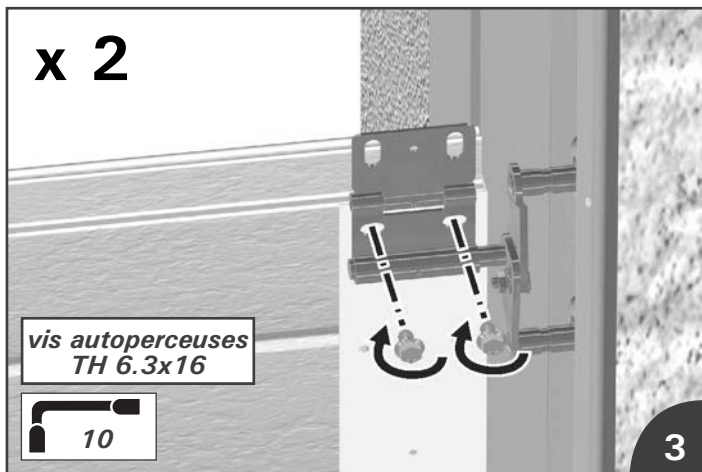
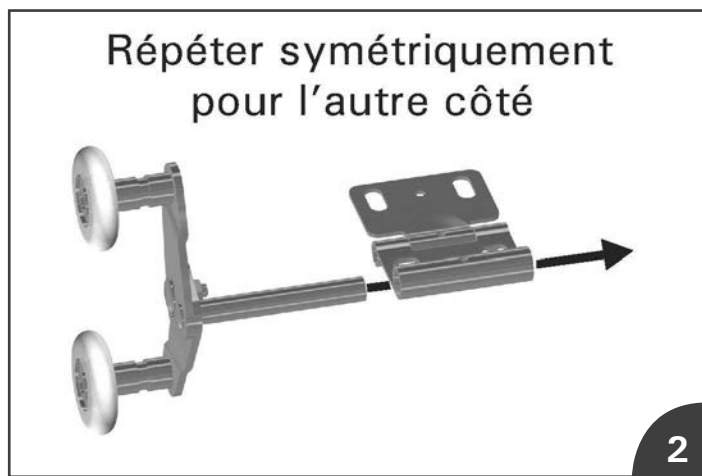
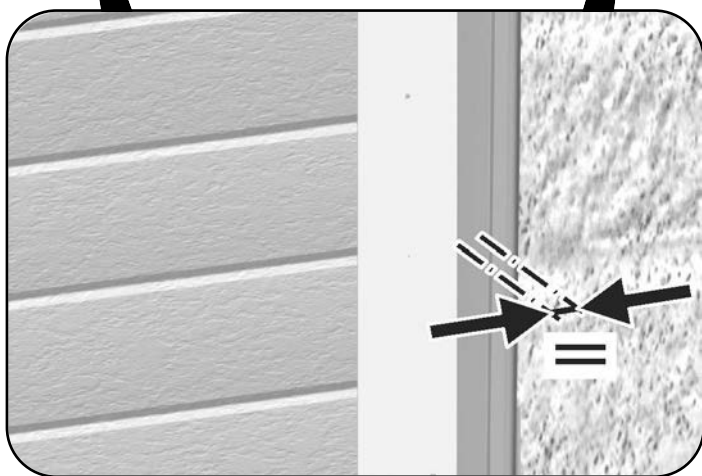
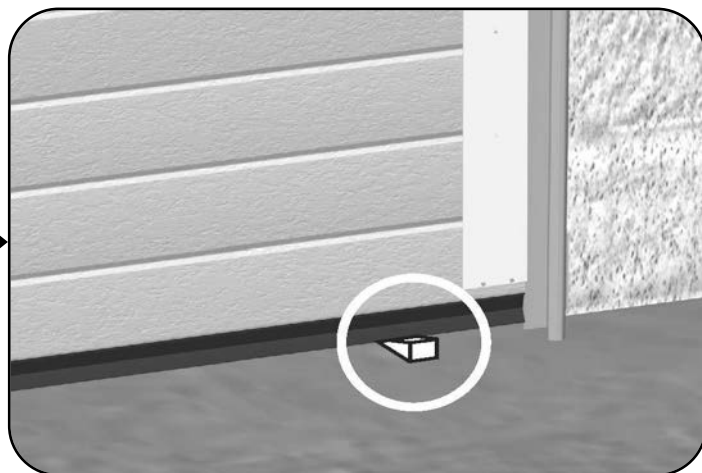
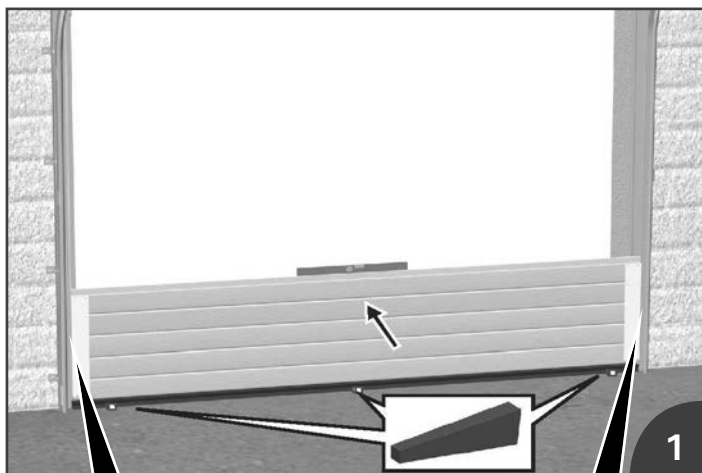

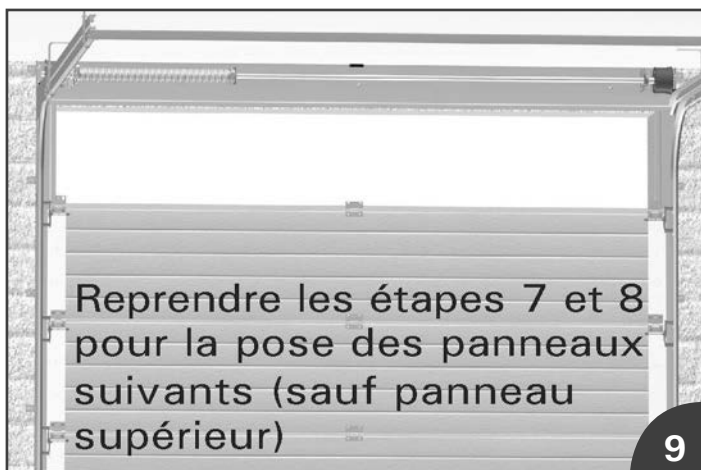
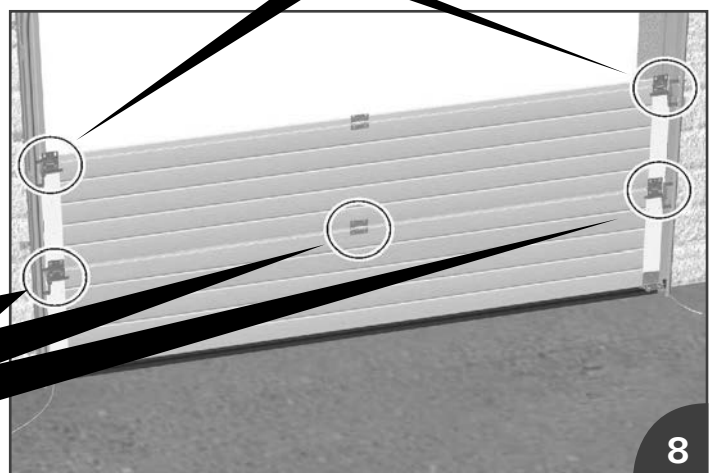
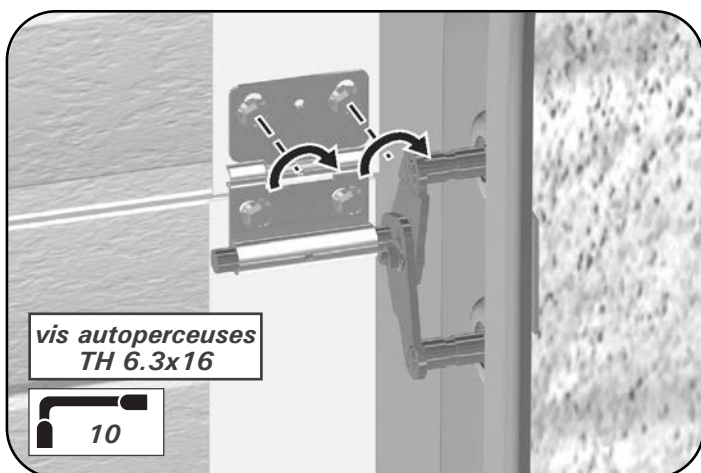
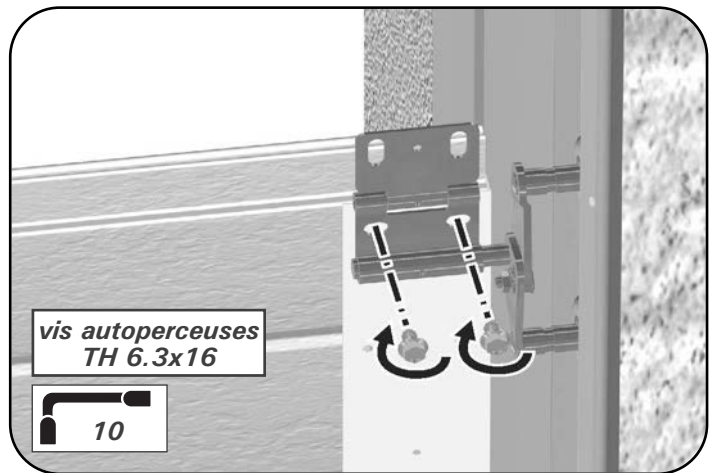
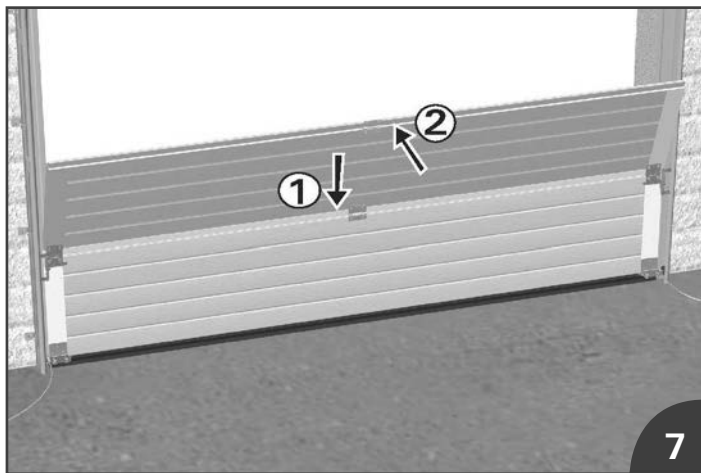
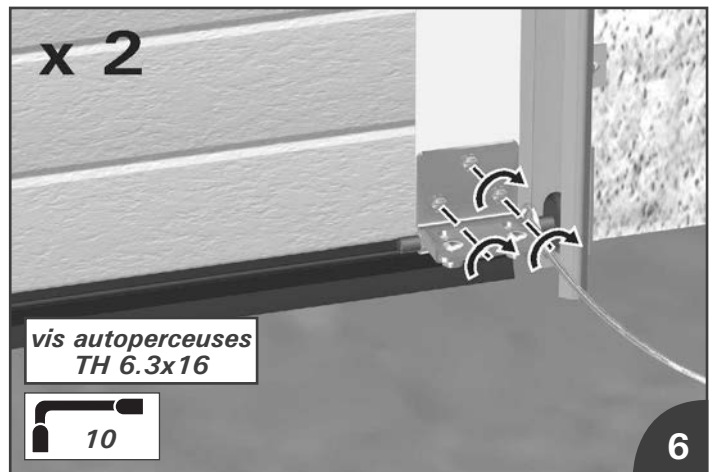
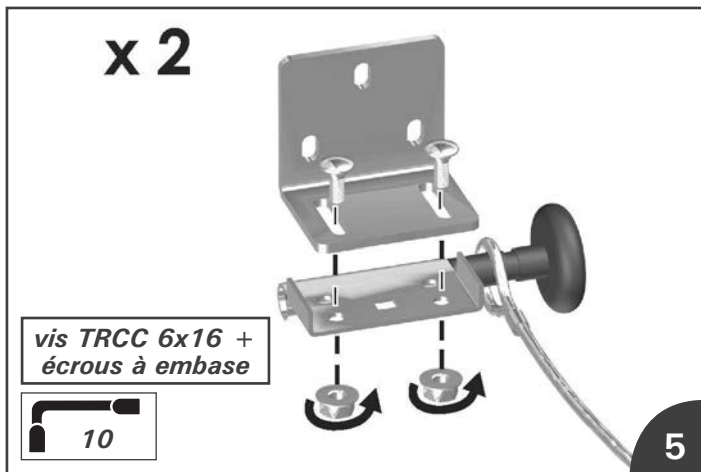

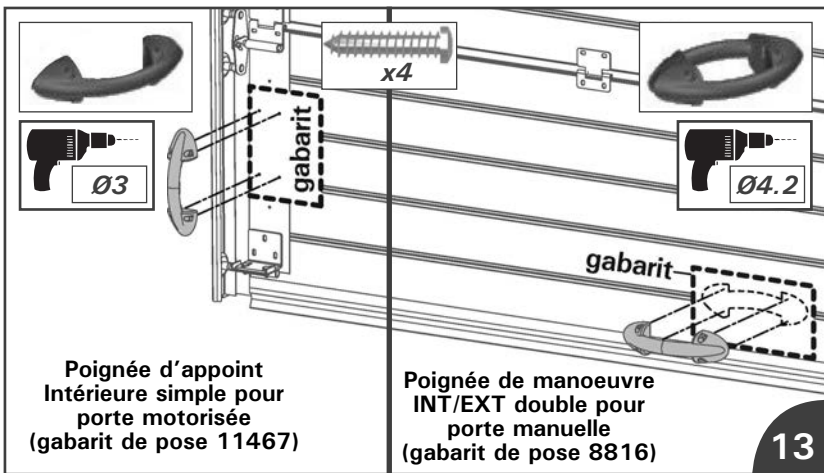
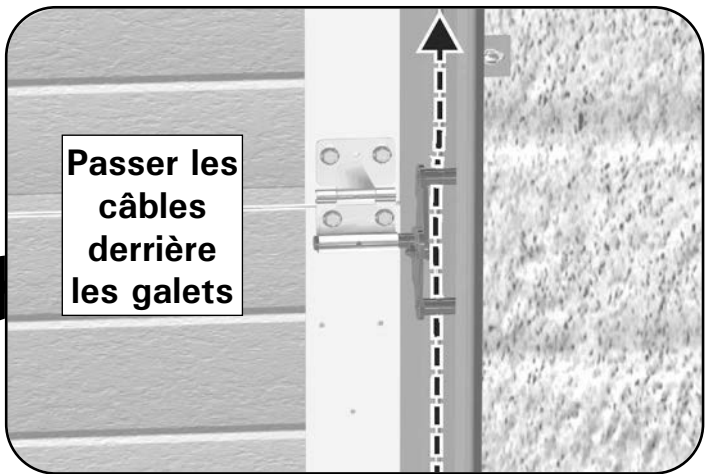
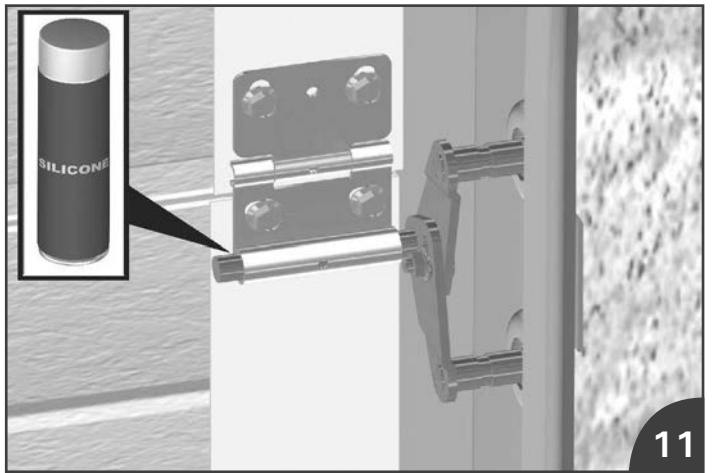
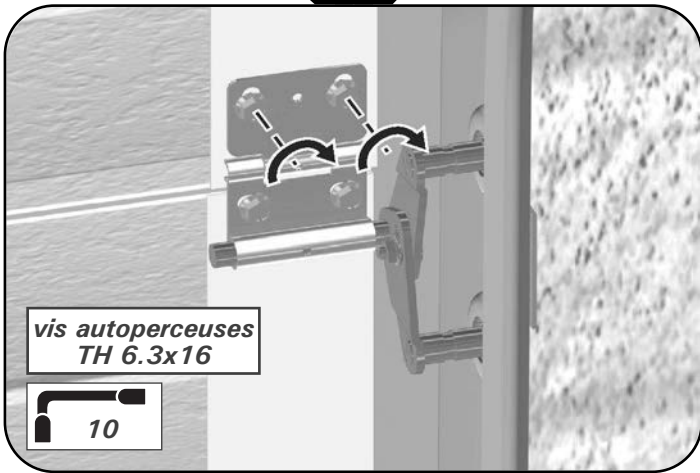
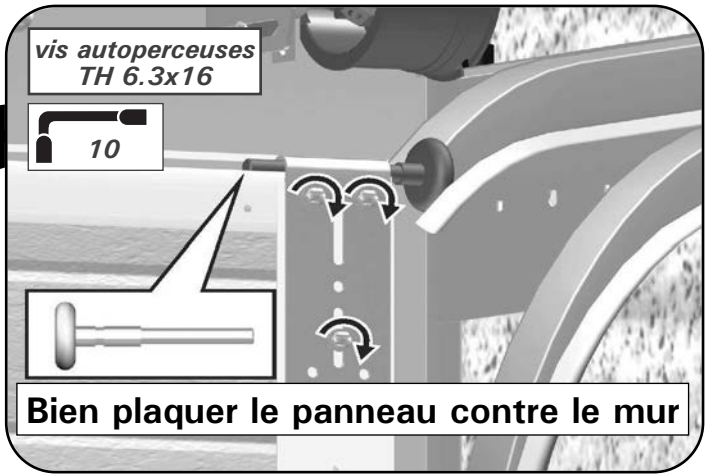
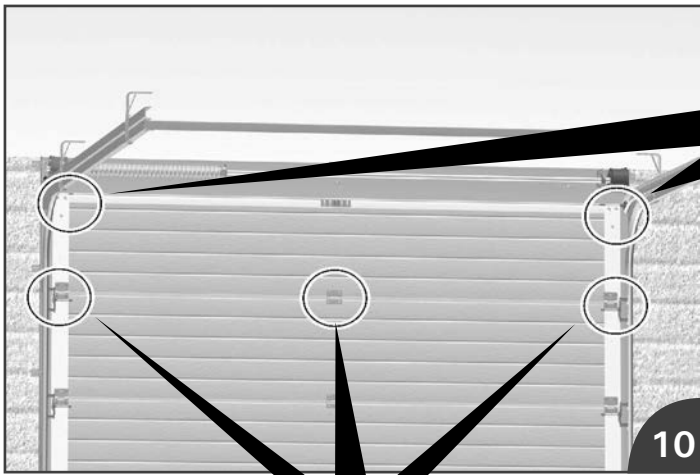

Equilibrage

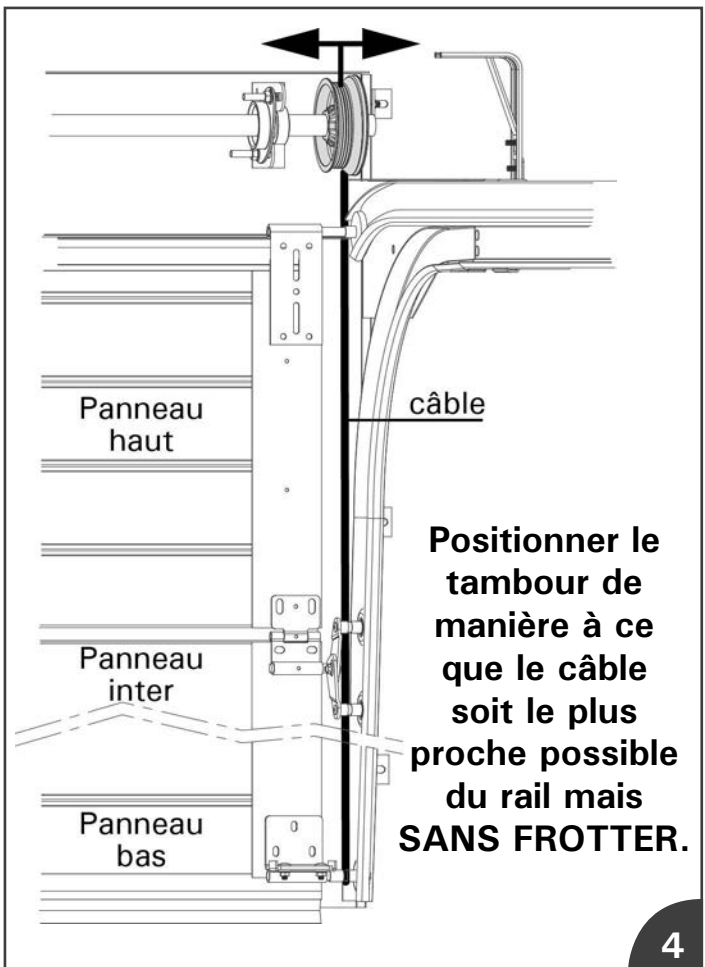
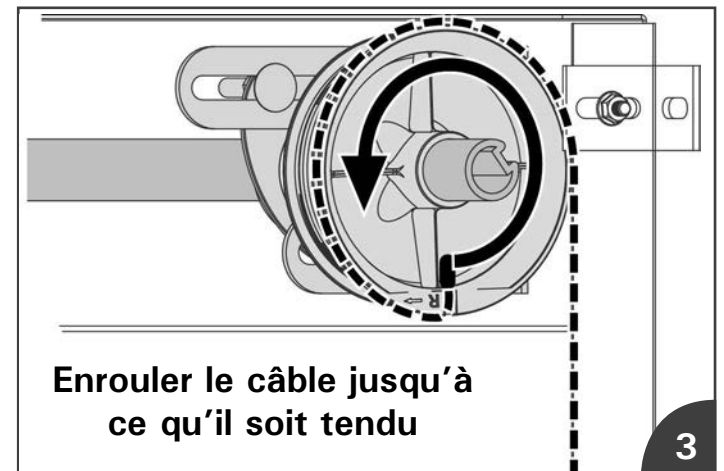
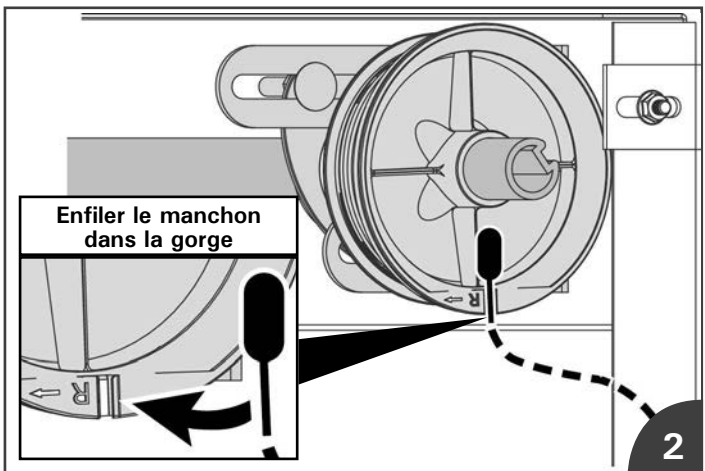
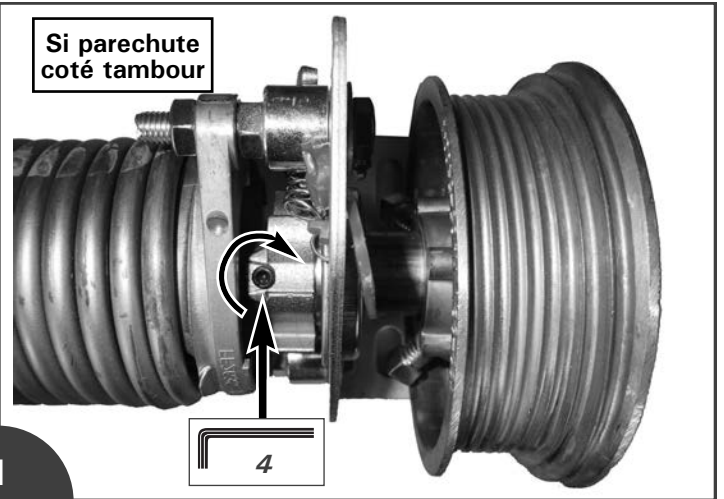
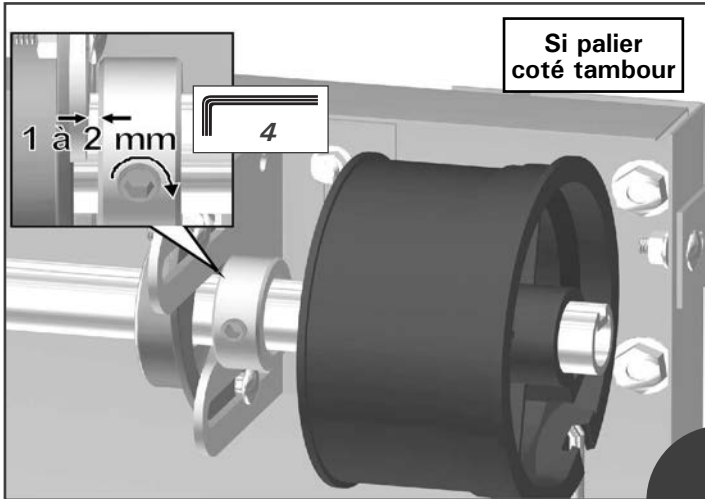

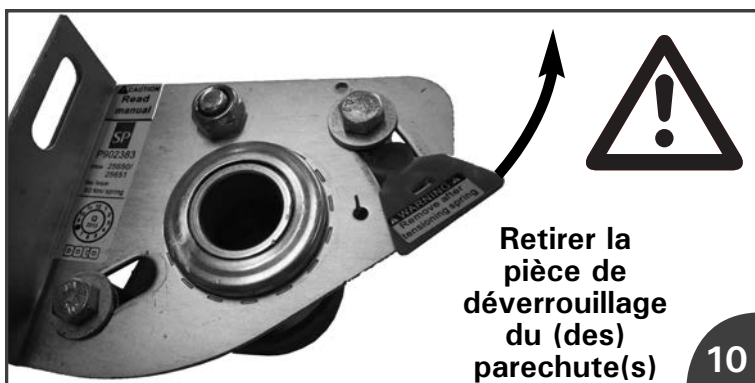
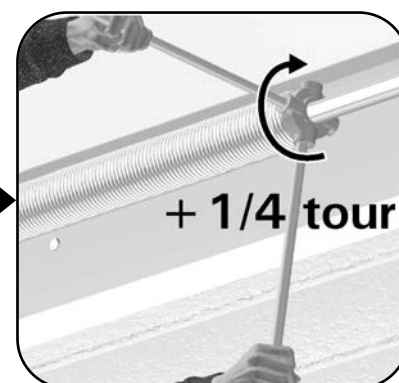
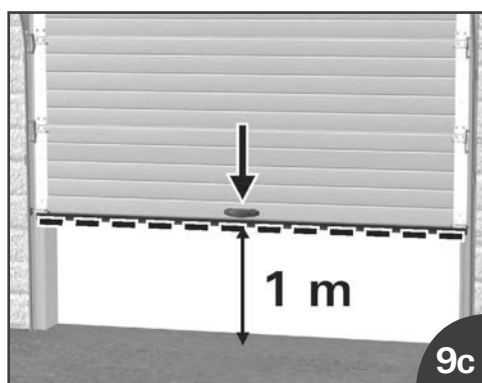
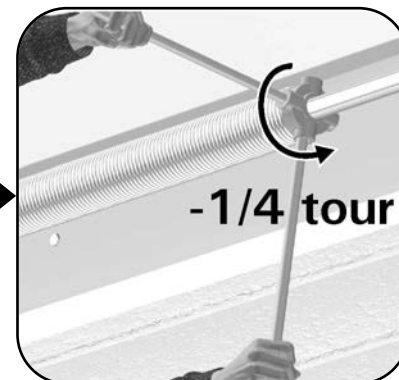
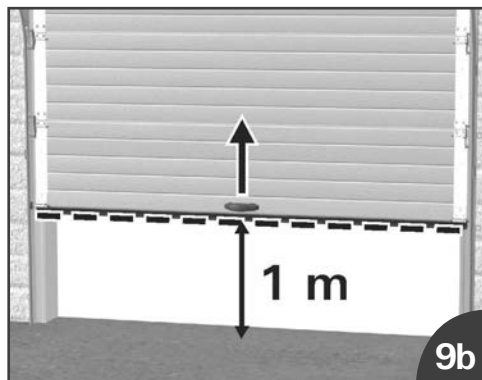
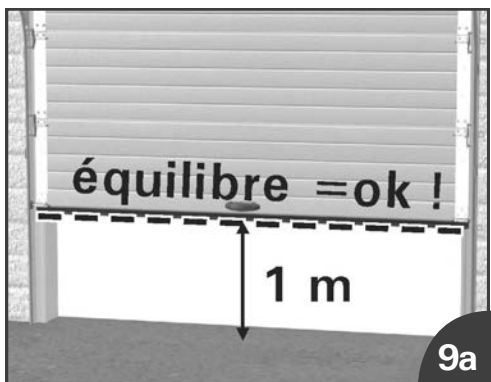
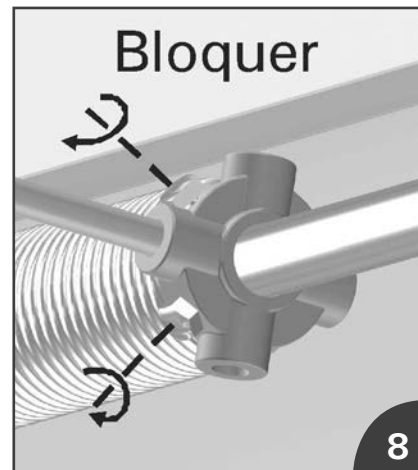
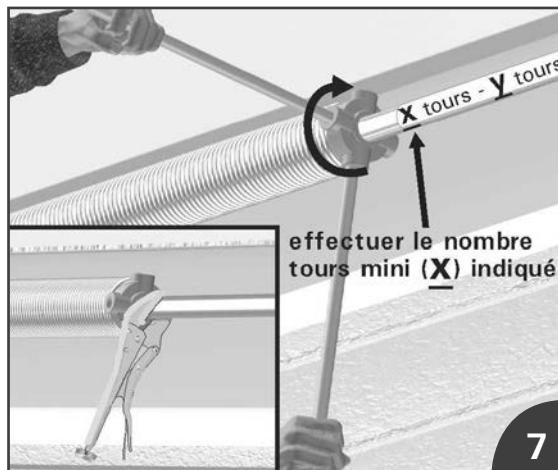
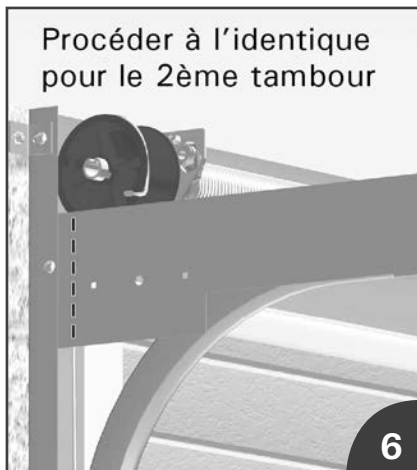
D

Démontage

Procéder à l'envers des opérations de montage.

Prendre toutes les précautions nécessaires face au risque de chute des éléments suspendus lors du démontage de ceux-ci.

Etre particulièrement vigilant lors de la dépose des ressorts de compensation : insérer des barres d'acier dans les alvéoles des mandrins avant de les débloquer et de les détendre progressivement. Ne démonter l'arbre qu'une fois les ressorts complètement détendus.